

# The Intertype Autospacer

---

... Its Functions  
Care, Operation  
and Adjustment

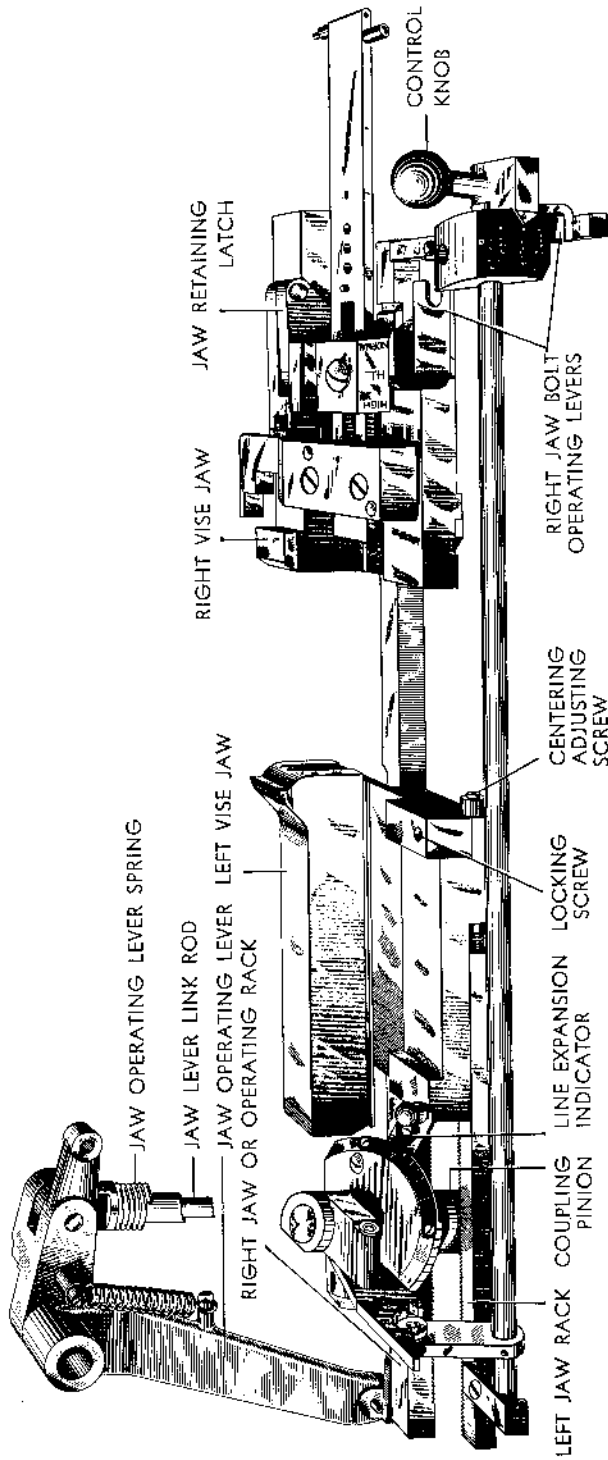

**FIG. 1.—View Showing the Working Parts on the Vise Cap.**

# THE INTERTYPE AUTOSPACER

## Its Functions, Care, Operation and Adjustment



This description is intended to serve two purposes. In the first place, it will instruct the operator in the working of the controls on Autospacer-equipped machines. Secondly, it will assist the machinist in caring for and maintaining the Autospacer.

**The Intertype Autospacer** is an automatic quadding and centering device. The chief differences between a quadding and non-quadding machine, as far as the operator is concerned, are the control knob and the line expansion indicator on the vise cap. The manipulation of these two controls is all the operator needs to do to get the full results of which the Autospacer is capable.

**The Control Knob** position determines whether the right vise jaw moves in to bring the line flush left, both jaws move in for centering, or the left jaw moves over to the line at the flush right position. Changing the position of the control knob should be done only when the machine is stationary in the normal position.

**When Changing Measure**, the knob must be at the *flush left* position and the left jaw against its stop after the measure has been set.

On machines equipped with the Mohr Saw it should be remembered that changing the setting of the saw also changes the setting of the left vise jaw. Therefore, when the saw is set, the control knob should first be put at *flush left*, and after the saw setting is made, the left jaw should be moved against its stop before the position of the control knob is changed again.

**The Line Expansion Indicator** is provided with a scale from 0 to  $3\frac{1}{2}$  ems. With the indicator set at 0, the machine will quad or center every line, with or without spacebands. If the indicator is set anywhere above 0, lines tighter than the indicated amount will justify, provided there are enough spacebands. Three or four bands for each em expansion is a good rule. The usual setting for justification of lines up to 12 picas is 2 on the indicator scale. For longer measures, up to  $3\frac{1}{2}$  ems expansion can be used. If there are insufficient bands for the necessary expansion of a line set within the indicated limit, the line will be lost—that is, it will not be cast—the same as a loose line on a non-quadding machine. If the line is short by more than the indicated amount, it will be quadded out automatically.

**The Assembler Slide** is provided with a *red pointer* which shows on the *stationary scale* how much the line lacks of being full. This is shown in Fig. 2. In the illustration the pointer indicates that the line lacks  $9\frac{1}{2}$  picas of being full. If this line is sent over, it will quad, regardless of the position of the line expansion indicator.

Assume that the line expansion indicator is set at 3. All lines to be justified must be set so that the pointer on the assembler slide is carried past 3 on the

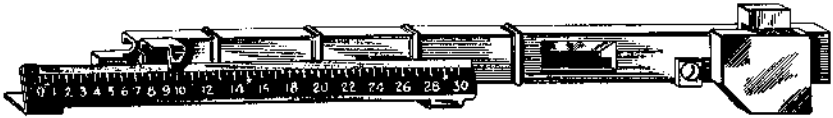

FIG. 2.—Assembler Slide and Scale

stationary scale. A line that does not carry the pointer up to 3 on the stationary scale will quad. It is advisable to avoid setting the line short by the exact amount shown on the line expansion indicator, as wear on the star wheel affects the accuracy of the reading of the stationary scale. A good rule is to allow at least  $\frac{1}{2}$  em leeway to be sure of the desired result. The assembler slide finger should be reset occasionally to compensate for wear on the star wheel.

The **Delivery Slide Long Finger** never needs setting on Autospacer machines. Short lines or even single matrices are brought up to it by the short finger, and the long finger is locked automatically for safe delivery. As the delivery slide returns, the long finger is left in the 30-em position. Cleaning the notched bar and wiping it over with an oily rag is occasionally necessary. The detent fulcrum pin and spring and the detent release should have an occasional drop of oil to assure free working. Surplus oil will foul matrices and should be avoided.

**Spring-Loaded Rails A, B and C** have been provided in the assembling elevator and the first elevator front jaw, as shown in Figs. 3 and 4. These rails press gently against the matrices to hold them in position. They are so adjusted as to hold the matrix line somewhat tighter on the left end in the

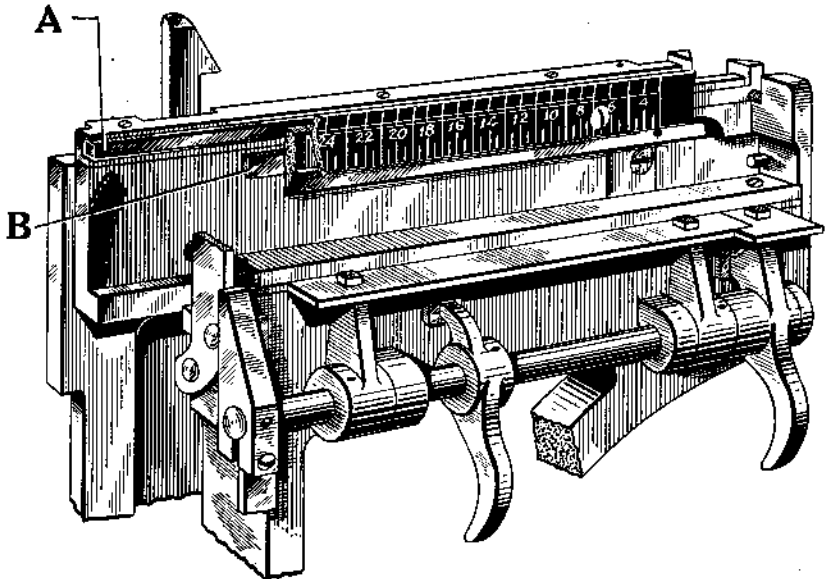

FIG. 3.—Assembling Elevator Showing Spring Rails A and B.

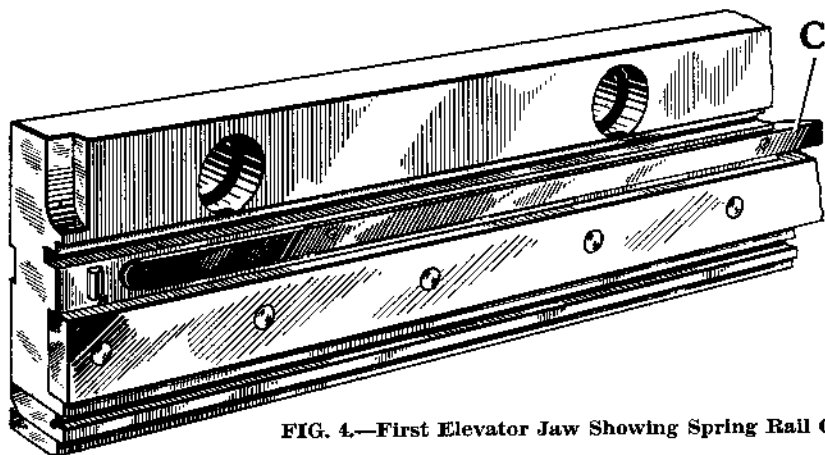

FIG. 4.—First Elevator Jaw Showing Spring Rail C.

assembling elevator. In the first elevator jaw the line stop holds the left end of the line and the rail presses more firmly on the right end of the line. The only attention necessary is to be sure that the rails are straight and free-working.

An **Automatic Line Stop**, shown in Fig. 5, is provided to control lines of any length in the first elevator jaw. During the transfer of the line, the line stop is brought back to the extreme right by the returning pawl attached to the transfer slide. If the spring-loaded *friction plunger A* is removed for any reason, it is important to replace it so that the sharp corner banks against projection *B* on the line stop. These parts should be lubricated with powdered graphite.

**Left Hand Indentions** on Autospace machines are set by means of a convenient knurled knob. To line up the last character on the left with the end of the slug, loosen the locking screw *A*, Fig. 6, on top of the vise closing bracket and adjust the knob until the left jaw is properly set. Then tighten the locking screw *A* and loosen collar *C* by unscrewing the set screw *B*. Set the scale on the collar so that 0 corresponds with the 0 on the bracket and tighten the set

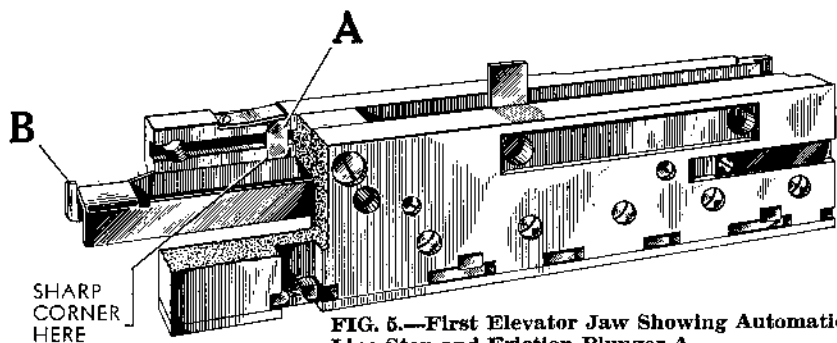

FIG. 5.—First Elevator Jaw Showing Automatic Line Stop and Friction Plunger A.

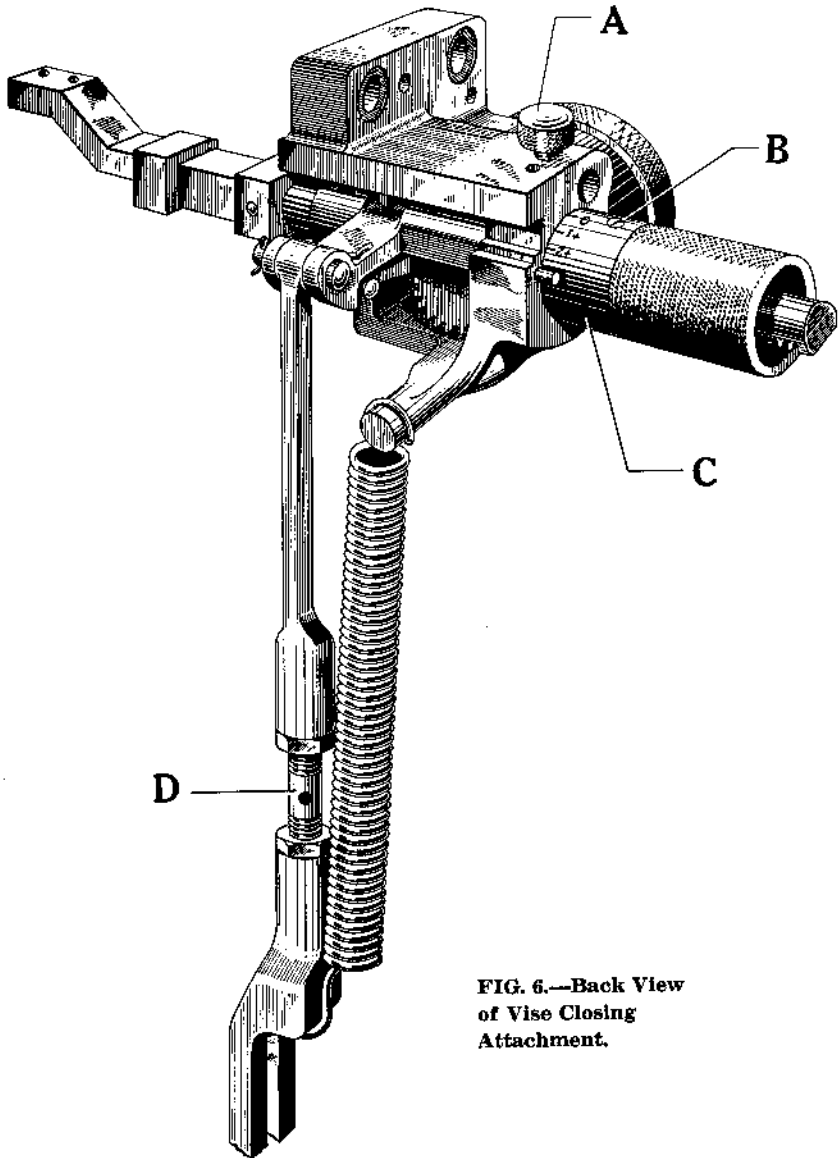

FIG. 6.—Back View  
of Vise Closing  
Attachment.

screw *B*. By loosening the locking screw *A* and turning the knob, uneven measures up to minus two or plus three points can be set.

The working of the Intertype Autospacer is simple. The closing and opening of the vise jaws is accomplished by means of a quadding lever operated from the main cam shaft.

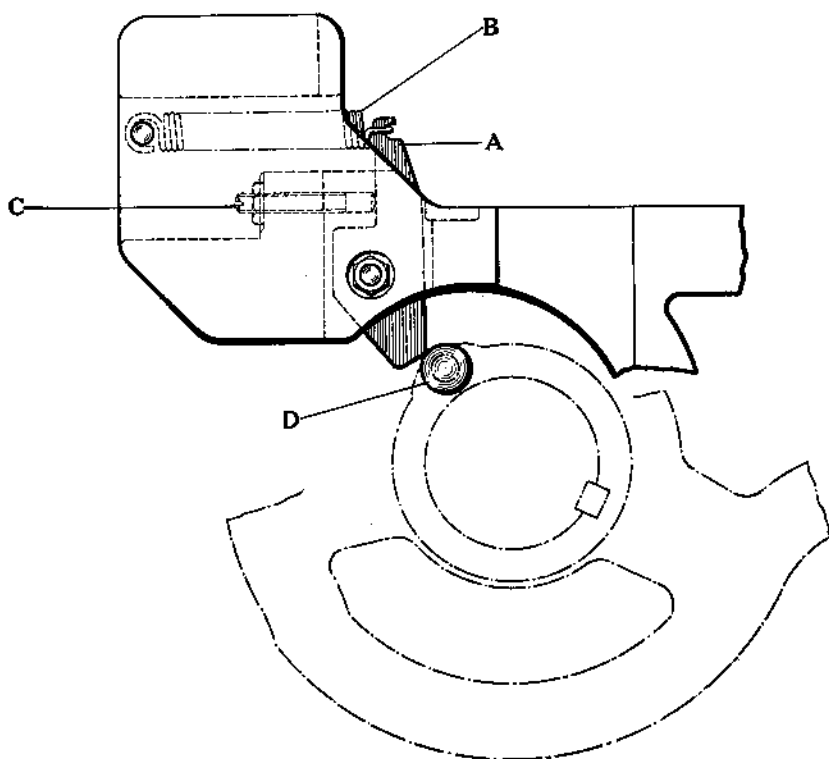

FIG. 7.—Quadding Lever Showing Cam Roller, Cam Rider and Adjustment.

The Quadding Lever is provided with a hinged cam rider *A*, held in place by a spring *B*, as shown in Fig. 7. In the operating position, this spring holds the cam rider against the adjusting screw *C*. The setting of the rider *A* is important and is made by sending over a 30-em line with spacebands and stopping the machine when the justification bar just touches the bands. In this position the cam rider *A* should be ready to drop off the cam roller *D*, as shown in the illustration. This adjustment is made by means of the screw *C*.

If this adjustment is not made correctly, the tension of the vise jaw operating lever spring, Fig. 1, is not released soon enough. In this case, the first drive of the spacebands is against the tension of this spring. Then, as the release finally occurs, the bands will be driven up with a slam, at the risk of damaging them.

Some machines that have seen long, hard service may occasionally fail to carry back the right jaw or operating rack sufficiently far to latch. This is caused by wear on the working parts of the quadding lever and its linkage. The length of the rod inside the vise jaw operating lever spring determines

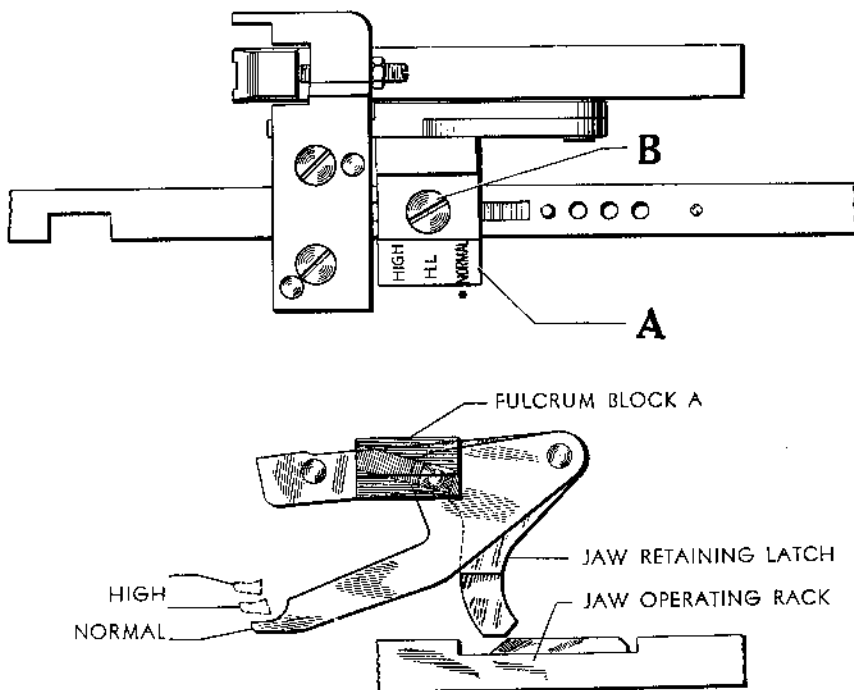

FIG. 8.—Top and Side View of Vise Jaw Retaining Latch.

how far back the rack will be carried. This spring is screwed onto the upper and lower links, and the rod floats inside the spring, forming a banking member for the return stroke of the lever.

The motion of the quadding lever is transmitted to the vise jaws through the jaw operating lever and the right jaw or operating rack. The control knob locks this rack to the right jaw in the *center* and *flush left* positions by means of the right jaw bolt operating levers, Fig. 1. The right jaw and its rack are disconnected at *flush right*. The left jaw rack is fixed to the left vise jaw. Between the racks is the coupling pinion. This is engaged with the racks in the *center* and *flush right* positions and is lifted free at *flush left*. As the first elevator descends, the right jaw rack is held against the increasing tension of the vise jaw operating spring by the jaw retaining latch, Fig. 1. When the elevator reaches the vise cap, the retaining latch is tripped, releasing the rack. At this point the quadding lever is on the high point of the cam and the resulting tension of the vise jaw operating spring is at its maximum. This spring pressure closes the jaws according to the setting of the control knob.

**The Jaw Retaining Latch** is set by moving the fulcrum block A, Fig. 8. The alignment stop bar is set in the *normal* position and the machine is brought around until the first elevator is resting on the vise cap. The elevator



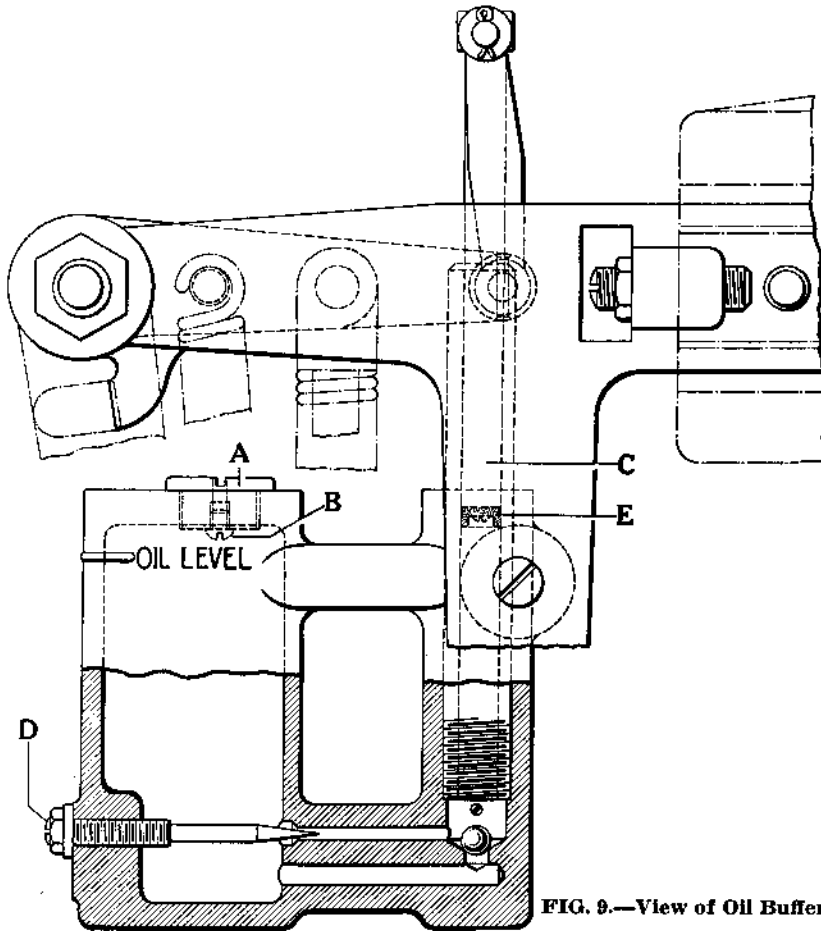
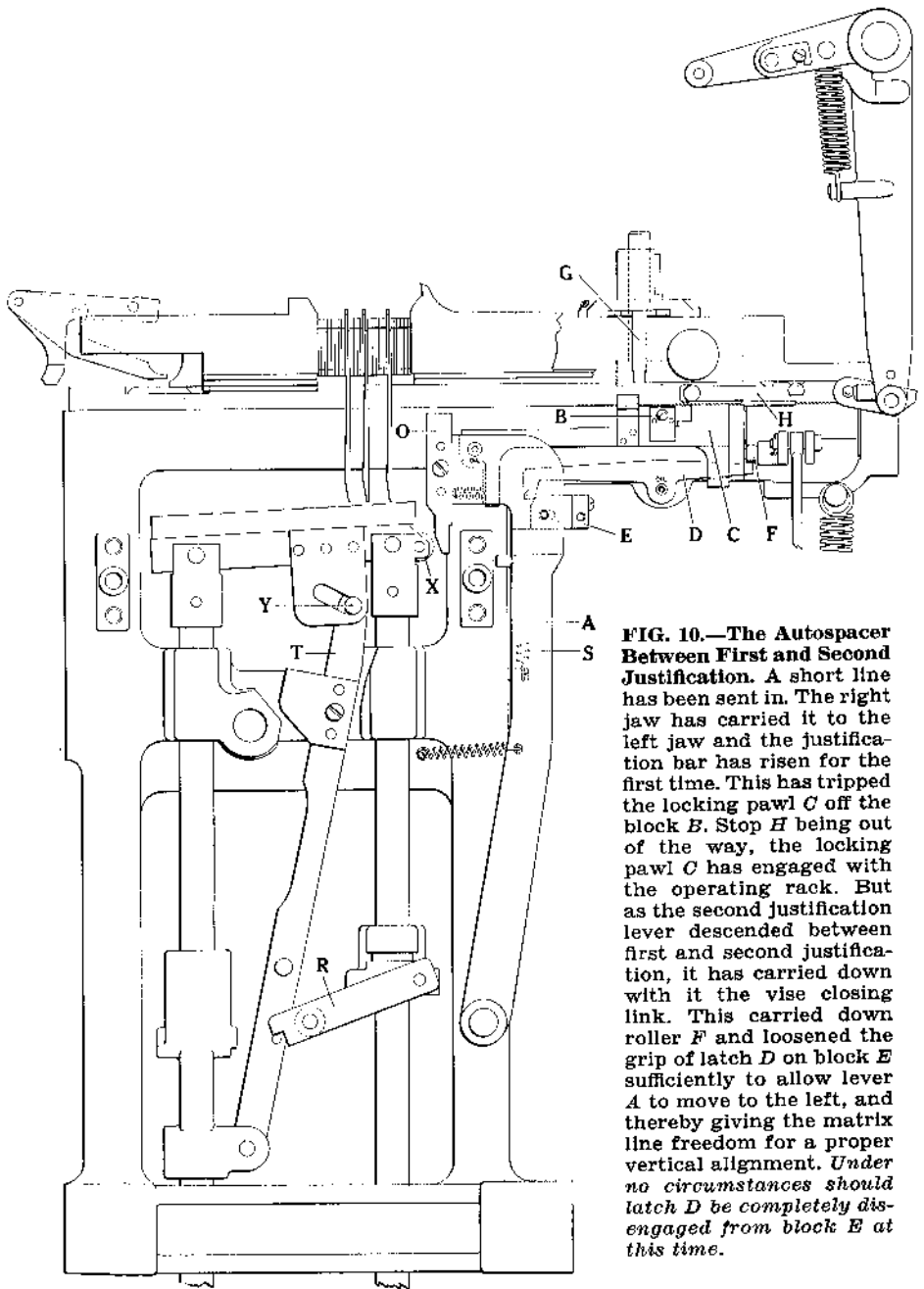

FIG. 9.—View of Oil Buffer.

is then raised and a .093" feeler gauge is put under the banking screw. In this position, the fulcrum block screw *B* is loosened, the block *A* is moved until the latch just releases the jaw operating rack, and the screw *B* is retightened. No further adjustment is necessary for the *headletter* or *high* positions. As the alignment stop bar is moved to *high*, *headletter*, or *normal* positions, the releasing lever of the retaining latch is automatically positioned for a correctly timed release. This is shown in the lower section of Fig. 8.

If the fulcrum block is set too far to the left, the jaws will not be released at all. If the setting is too far to the right, the release will be premature. A premature release of the vise jaws will cause unnecessary rubbing of the end matrices by forcing the line between the tight jaws.

An Oil Buffer, Fig. 9, is provided to give a cushion stroke to the vise jaws



**FIG. 10.—The Autospacer Between First and Second Justification.** A short line has been sent in. The right jaw has carried it to the left jaw and the justification bar has risen for the first time. This has tripped the locking pawl *C* off the block *B*. Stop *H* being out of the way, the locking pawl *C* has engaged with the operating rack. But as the second justification lever descended between first and second justification, it has carried down with it the vise closing link. This carried down roller *F* and loosened the grip of latch *D* on block *E* sufficiently to allow lever *A* to move to the left, and thereby giving the matrix line freedom for a proper vertical alignment. *Under no circumstances should latch *D* be completely disengaged from block *E* at this time.*

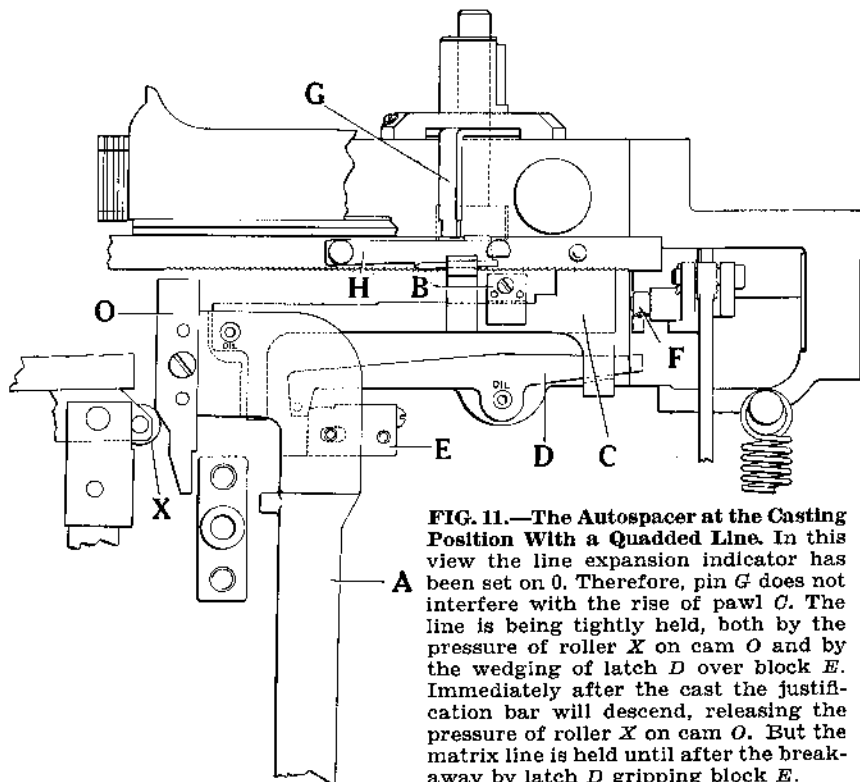
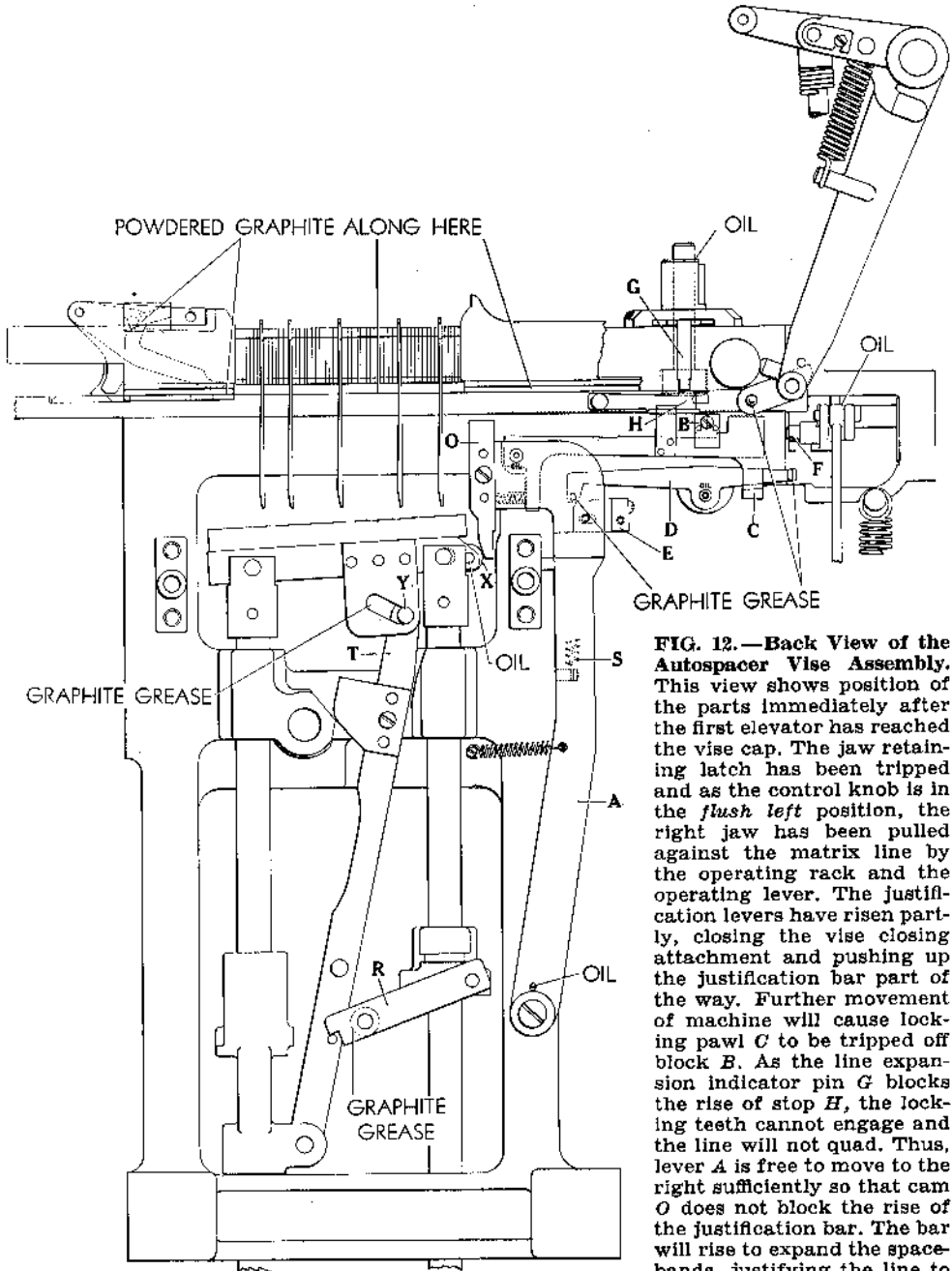

**FIG. 11.**—The Autospacer at the Casting Position With a Quadded Line. In this view the line expansion indicator has been set on 0. Therefore, pin *G* does not interfere with the rise of pawl *C*. The line is being tightly held, both by the pressure of roller *X* on cam *O* and by the wedging of latch *D* over block *E*. Immediately after the cast the justification bar will descend, releasing the pressure of roller *X* on cam *O*. But the matrix line is held until after the break-away by latch *D* gripping block *E*.

as they are brought together. This buffer needs little or no attention when once set and filled with oil. When new machines are shipped from the factory a screw *B* is put in the cap *A* to prevent oil leakage. This screw must be removed before the machine is put in operation and the vent must be kept open in service. The oil chamber should be kept filled to the mark when piston *C* is at the bottom. Medium heavy D. T. E. oil (Socony Vacuum Oil Co.) or a similar light motor oil should be used. The leather cup washer *E* at the bottom of the piston *C* provides an oil-tight seal. The proper cushion stroke for the jaws is obtained by setting the needle valve *D*. It will be found that on new machines this adjustment should be checked after they have been in service for a while. As the parts wear in, friction becomes less and the oil buffer may have to be set to exert a greater cushioning effect.

Let us now take up the operation of the machine again. We left it with the vise jaws having been closed through the action of the jaw operating lever.

**When Casting Quadded or Centered Lines**, the first justification lever rises, the roller *X* on the justification bar engages the lower surface of lever cam *O*, and this pushes the lever *A* to the right as shown in Fig. 10.



**FIG. 12.—Back View of the Autospace Vise Assembly.** This view shows position of the parts immediately after the first elevator has reached the vise cap. The jaw retaining latch has been tripped and as the control knob is in the *flush left* position, the right jaw has been pulled against the matrix line by the operating rack and the operating lever. The justification levers have risen partly, closing the vise closing attachment and pushing up the justification bar part of the way. Further movement of machine will cause locking pawl *C* to be tripped off block *B*. As the line expansion indicator pin *G* blocks the rise of stop *H*, the locking teeth cannot engage and the line will not quad. Thus, lever *A* is free to move to the right sufficiently so that cam *O* does not block the rise of the justification bar. The bar will rise to expand the spacebands, justifying the line to its full length.

By this time, the roller *F* has risen, as the vise closing screw comes toward its closed position. If the line expansion indicator pin *G* is set at the 0 location, as in Fig. 11, or the line lacks more than the indicated amount of being full, as in Fig. 10, the locking pawl *C* is pushed off block *B* and the teeth of the locking pawl *C* engage with those of the operating rack, locking the jaws. The pawl *C* is allowed to rise to the locking position in these cases because the indicator pin *G* does not block stop *H*. As the teeth of the pawl and rack engage, the lever *A* comes over to the right sufficiently for the end of latch *D* to lock over block *E*. As the justification bar rises further, it contacts the upper cam surface of the lever cam *O* and thus tightens the line. Between justifications, the vise closing link descends about half way. The roller *F* descends, engaging latch *D* and relaxing the grip on block *E*. Lever *A* is thus allowed to move slightly to the left, loosening the engagement of the locking teeth. This frees the matrix line and allows it to settle into position for vertical alignment as in a non-quadding machine. The loosening of the locking teeth is essential, but it is equally important that the teeth should not disengage completely at this time.

With no loosening of the line between justifications, the alignment of the matrices will be faulty for the cast. If the locking teeth are completely disengaged, it is quite possible that in locking again for second justification a tooth will be skipped. In this event, the vise jaws will be separated an extra  $\frac{1}{2}$  em. This may not be taken up in second justification, in which case metal is very likely to work in between the matrices, with consequent fins and hair-lines.

At second justification, the latch *D* tightens over block *E* again and remains there when the cast is complete and until after the slug has been withdrawn from the matrix line. This holding of the matrix line until after the breakaway is the second important function of latch *D*.

If the setting of block *E* is wrong, latch *D* may have too much or too little bite on the block for certain lengths of line. If this happens the matrix line will be loosened prematurely after the cast. The result will show in a slurring of the characters on the slug.

During the cast the roller *X* on the justification bar is wedging the lever *A* over and thereby keeping the matrix line firmly clamped between the vise jaws. This is shown in Fig. 11.

**When Casting Full Lines with Spacebands**, as in Fig. 12, the line expansion indicator is set for the desired amount of expansion. If a line is set within the indicated amount, the indicator pin *G* prevents the locking pawl *C* from pushing up stop *H* and engaging the rack teeth. This leaves lever *A* free to move over far enough to allow the justification bar full scope to drive the spacebands for justification.

If the line is short by more than the indicated amount, stop *H* is carried past the indicator pin *G*. As the justification bar rises, lever *A* is moved to the right by the roller *X*, until the locking pawl *C* is pushed off block *B* to engage

the teeth of the rack. As the justification bar continues up, the spacebands are expanded until the roller *X* contacts the upper cam surfaces of cam *O*. This explains how, with the line expansion indicator set for normal operation, short lines will quad out automatically.

As on non-quadding machines, the spacebands are pushed up for justification first at one end of the line and then at the other. But, contrary to the action of non-quadding machines, the spacebands on the left end of the line are pushed up first. As always, the second justification occurs with the justification bar straight. This is accomplished by the cross links *R* and *T* between the justification rods. The link *T* has a pin *Y* which operates in a slotted cam fastened to the justification bar. This cam is so arranged that when the first justification lever rises, the bar is held at the proper angle, and when both levers rise, the bar is carried up level. A small amount of graphite grease should be applied to this slotted cam and to the roller on link *R*.

Most of the parts mentioned are fixed in position and require no adjustment. There are, however, a few settings which are of vital importance.

**The Block *E*** must be set so that latch *D* locks over it at the same time that locking pawl *C* drops off block *B*. But, also, latch *D* must have sufficient bite on block *E* to prevent releasing the line of matrices until the slug has been withdrawn. The amount of this bite will vary with different length lines, but under no conditions should this be less than  $1/16''$ . The best way to test this setting is to send over a short line, say **ETAOIN**, and observe the action of latch *D* and the amount of bite on block *E*. Then send over the same line with a thin space and observe again. Continue thus until the original line plus ten thin spaces has been tried. The setting of the block will be right if the smallest amount of bite is  $1/16''$ . The amount of bite is best observed at the casting position.

**The Latch Spring *S*** must have sufficient tension to hold the matrix line tightly between the jaws at the time of breakaway. A load of 15 to 17 pounds should stretch this spring to  $4\frac{1}{2}''$  between the loops. The result of a weak spring will be similar to a poor adjustment of block *E*, when the characters on the slug face are slurred.

The vise closing cam is provided with two steel shoes. The first shoe determines the position of the vise closing screw between first and second justifications. The second shoe determines the position of the vise closing screw with the machine at transfer position. With the machine at transfer position, the turnbuckle *D* on the vise closing link is adjusted so that roller *F* on the vise closing screw depresses latch *D* to carry down locking pawl *C* until it can slip under block *B*. There should be a clearance between block *B* and locking pawl *C* of approximately  $1/64''$ .

Between first and second justifications, roller *F* on the vise closing screw depresses latch *D* to relax the grip on block *E*. This permits lever *A* and locking pawl *C* to move to the left sufficiently to free the matrix line from jaw pressure for vertical alignment. Latch *D* should have about  $1/32''$  engagement with block *E* at this time and should *not* disengage completely.

**Centering** on the Intertype Autospace is always accurate, provided the proper setting is correctly made. The adjustment for centering is easily made by moving the left vise jaw with respect to its rack. To do this, the centering adjusting screw, Fig. 1, that fastens the jaw to the rack is turned. Lest this screw work loose and destroy the setting, a locking screw is provided, which bears down on the adjusting screw from the top. The adjustment has to be made with the left jaw as far to the right as it will go. In this position the locking screw is directly under a hole in the vise cap and may be reached with a small screw driver. The adjusting screw is then turned by a screw driver put through the hole in the steel plate on the right-hand end of the vise cap. Turning this screw clockwise moves the center line to the left. Be sure to tighten the locking screw after this adjustment is made. The method of finding the proper center position is to set the knob for *center* and cast two blank slugs. A fine line may be seen across the face of the slugs in the middle where the vise jaws have met. If these slugs are placed back to back, the error from center may be seen by these fine lines. The left vise jaw rack should be so adjusted that these lines coincide exactly.

As is seen above, there are several settings which must be correct for the proper working of this device. But let us emphasize that quite as important as any setting is the need for cleanliness and proper lubrication throughout the machine. The Autospace is a very carefully made mechanism, but dirt in vital spots will disturb its functioning. There is no excuse for neglect, because disassembly of the parts has been made so easy. The points requiring lubrication and the proper materials to use are shown in Fig. 12.

To remove the right jaw or operating rack, open the vise, set the vise jaws for 30 ems, set the control knob to *flush right* and trip the retaining latch with the right hand. At the same time, pull the rack with the left hand until the left jaw meets the right. In this position, change the control knob to *flush left*. This releases the right jaw from the rack and it may be pulled out completely. With this rack out, the inside of the vise cap is available for inspection, cleaning with high test gasoline, and lubrication with powdered graphite. The rack should be given the same treatment. Reassembling the rack is accomplished just as easily by reversing the above procedure.

To remove the complete mechanism from the vise cap, first remove the wing pin at the bottom end of the vise closing link, being careful not to lose the small roller in the link. The left vise jaw support overlapping the top of lever *A* is then removed. Then, in turn, take off the line expansion indicator and the left vise handle. Then, with the removal of the three bolts holding the vise closing bracket, the whole mechanism, including vise jaws and racks, can be taken out. Assembly of these parts is in the reverse order, and there are no settings to bother the machinist.

It is easily seen from the foregoing account that the Autospace is simple and rugged in construction. With a minimum of attention, it will give trouble-free service over a long period of time, turning out work of the traditional Intertype standard of excellence.

## THE AUTOSPACER AND THE JUSTIFIED QUADDING ATTACHMENT

The most recent Intertype autospacers are equipped with a device known as the justified quadding attachment. This attachment increases the range of work possible with the autospacer without affecting its original features. With the justified quadding attachment, it is possible to set fully justified lines automatically with uniform indentions up to 15 ems on the right of the line. Indentions of any length on the left of the line are obtained as usual by setting the left vise jaw by means of the vise adjusting knob. The original features of the autospacer are still present. Lines can be set flush left, flush right or center by means of the control knob.

From the operator's viewpoint, the chief differences between the ordinary autospacer and the new type with the justified quadding attachment are the operating lever *A*, Fig. 13, the knob *B* and the two scales *D* and *E*. Lever *A* controls the engagement and disengagement of the justified quadding device. When the lever is moved to the left, the justified quadding attachment is placed in operation. When the lever is moved to the right, the attachment is disengaged from operation and the device is ready to be used for ordinary quadding and centering of lines of various lengths and also for setting fully justified lines. The knob *B* controls the movement of pointer *C* along the Justified Indention Scale *D* and the Normal Scale *E*. The pointer is moved by lifting knob *B* slightly and turning the knob in the desired direction. When the knob is dropped, the pointer is locked in position.

The Normal Scale corresponds exactly in function to the scale formerly used on the line expansion indicator shown in Fig. 1. When the pointer *C*, Fig. 13, is on the Normal Scale *E* and operating lever *A* is to the right, the autospacer functions in every respect as described on the preceding pages. In setting ordinary composition having full justified lines as well as short lines, pointer *C* is moved to the Normal Scale and set for the desired amount of expansion. Operating lever *A*, of course, is swung to the right under the Normal Scale. As on the ordinary autospacer, full lines with spacebands will justify and short lines will quad automatically. To quad or center all lines, simply set the pointer on zero and move the operating lever to the right the same as for full lines.

**Use of the Justified Quadding Attachment.** As stated previously, the justified quadding attachment makes it possible to set fully justified lines with indentions in half-em increments up to 15 ems on the right and indentions of any length on the left. The indention on each side of the line is controlled separately. Indentions on the right of the line are set by lifting knob *B*, Fig. 13, and turning the knob until pointer *C* registers with the desired setting on the Justified Indention Scale. Indentions on the left of the line are obtained as usual by moving in the left vise jaw by means of the vise adjust-



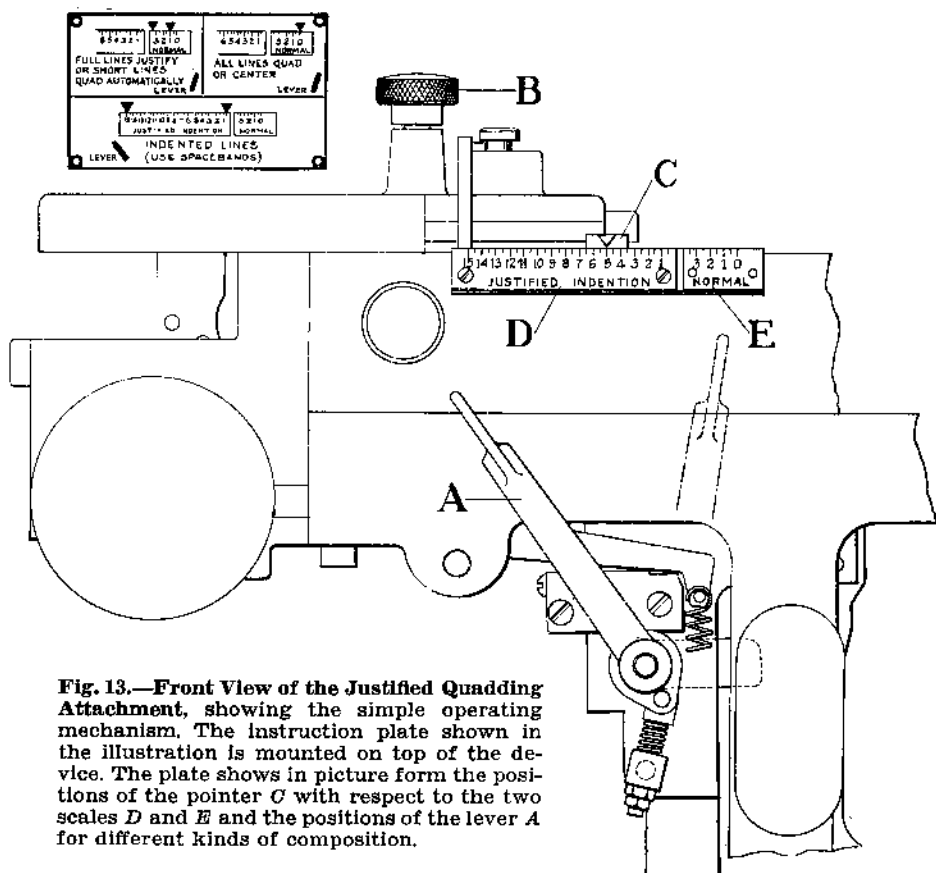

**Fig. 13.—Front View of the Justified Quadding Attachment, showing the simple operating mechanism. The instruction plate shown in the illustration is mounted on top of the device. The plate shows in picture form the positions of the pointer *C* with respect to the two scales *D* and *E* and the positions of the lever *A* for different kinds of composition.**

ing knob. Since the left and right indentions are controlled separately, it is possible to locate the type line in any desired position on the face of the slug. For example, suppose that a 20-em line is to be set on a 30-em slug with a 7-em indentation on the right and a 3-em indentation on the left. In this case, pointer *C*, Fig. 13, should be set on 7, operating lever *A* should be moved to the left and the left vise jaw should be moved in until the vise indicator rod is set on 27 ems. The assembler slide, as usual, is set for the length of the line, which in this case is 20 ems.

After the length of the line has been determined and the indentation settings have been made, matrix lines are assembled in the same manner as on a regular machine. Since the lines are expected to justify to a predetermined length, provision must be made for expansion of the spacebands. *The assembled lines should be slightly shorter than the measure being set.* Lines which are three picas short of the measure being set will justify if there are enough space-

bands for the necessary expansion. Lines short by more than three picas will quad out automatically if there are at least three spacebands in the line. As a general rule, all lines must contain at least two spacebands of ordinary thickness in order for the machine to cast.

**Correct adjustment of the assembler slide finger** is highly important on a machine equipped with the justified quadding attachment. When setting lines with indentions on the right, the distance between the vise jaws is greater than the length of the line being set. Since the right vise jaw does not move until the line of matrices and spacebands has been positioned between the vise jaws, it is possible to send overset lines in to the casting mechanism without stalling the machine. Consequently, an overset line will cast and since the line is already longer than the desired measure, the indention on the right of the overset line will be less than that on the other slugs. The adjustment of the assembler slide finger should therefore be checked periodically to insure accuracy at all times. The finger should be set slightly short to offset the slight amount of wear on the assembler star wheel.

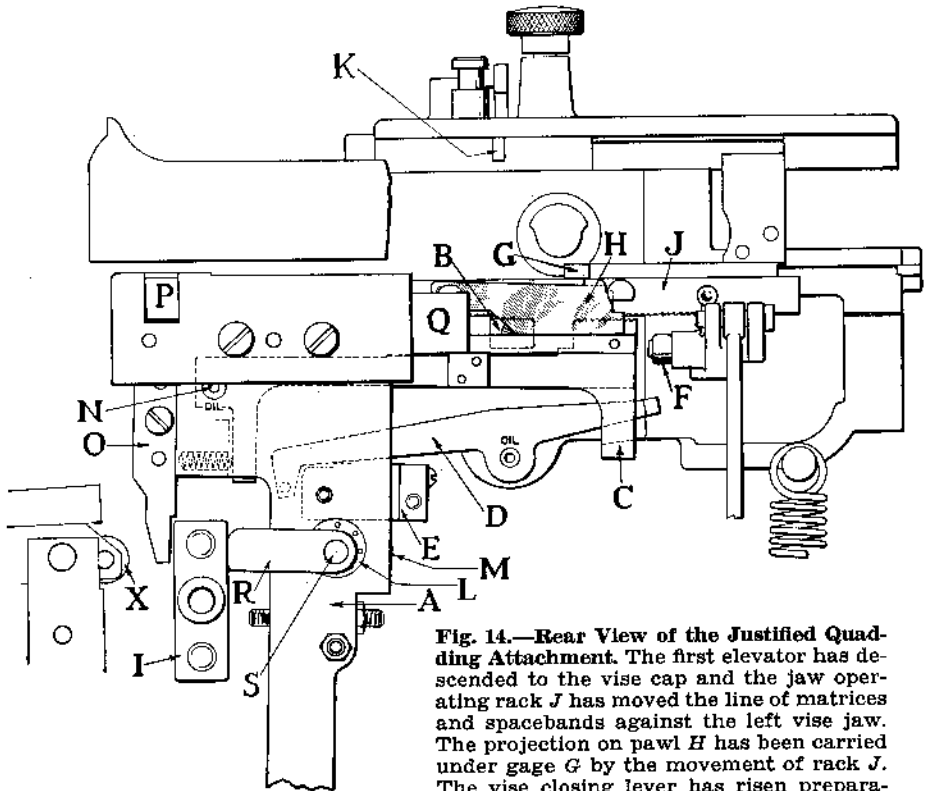

**Fig. 14.—Rear View of the Justified Quadding Attachment.** The first elevator has descended to the vise cap and the jaw operating rack *J* has moved the line of matrices and spacebands against the left vise jaw. The projection on pawl *H* has been carried under gage *G* by the movement of rack *J*. The vise closing lever has risen preparatory to first justification.

### Mechanism of the Justified Quadding Attachment

The basic operating mechanism of the justified quadding attachment consists of the vise jaw rack pawl lever cam *R*, Fig. 14, the vise jaw rack pawl rest *PQ*, the line spread pawl *H* and the line spread and indentation pawl gage *G*. Cam *R* is pinned to a shaft on the front end of which is fastened the operating lever *A*, Fig. 13. The cam controls the position of the vise jaw rack pawl lever *A*, Fig. 14, and consequently fixes the position of the vise jaw rack pawl *C*. The pawl rest *PQ* is provided to take the place of block *B* when the justified quadding attachment is being used. The line spread pawl *H* and the indentation pawl gage *G* control the engagement of the vise jaw rack pawl *C* with the vise jaw rack *J*.

When Using the Regular Autospace Feature without justified quadding, operating lever *A*, Fig. 13, is moved to the right. This withdraws the high point of cam *R*, Fig. 14, away from the mold disk locking stud block *I*. Lever *A*, cam *O* and pawl *C* then move to the left and assume the positions they normally have on the regular autospace. Cam *O* moves into line with roll *X* on the vise justification bar and pawl *C* is engaged under block *B*. The actions of the machine, under these conditions, are exactly as outlined in the description of the regular autospace.

When Using the Justified Quadding Attachment, the operating lever is moved to the left. This causes the high point of cam *R* to bear against the mold disk locking stud block, as shown in Fig. 14. Lever *A* is thereby moved to the right until cam *O* is out of line with roll *X* on the vise justification bar. Consequently, the justification block will be permitted to make a full upstroke during first and second justification, because roll *X* will not contact cam *O*. This explains how the lines are fully justified when using the justified quadding attachment. The same movement of lever *A* to the right, of course, disengages pawl *C* from block *B*. The pawl rest *PQ* takes the place of the block when the justified quadding attachment is in use. The rest *Q* engages an auxiliary lug on pawl *C* and holds the pawl down until it is to be released.

As explained previously, knob *B*, Fig. 13, controls the movement of the pointer *C* along the Justified Indentation Scale and the Normal Scale. As the knob is turned to shift the pointer from one measure to another, indentation gage *G*, Fig. 14, is also moved a corresponding distance to the right or to the left. When the knob is dropped, both the pointer and the indentation gage are locked in position. The indentation gage *G* is a banking point for pawl *H*, which controls the engagement of the vise jaw rack pawl *C* with the rack *J*.

In Fig. 14, the parts of the justified quadding attachment are shown just after the first elevator has descended to the vise cap. The vise jaw retaining latch has been tripped, permitting the jaw operating lever to pull rack *J* to the right. The right vise jaw and the line of matrices and spacebands has been moved over against the left vise jaw. Since the assembled line has been set within 3 ems of the desired measure, rack *J* has moved far enough to the right to carry the projection on pawl *H* under gage *G*. *This basic relationship*

between pawl *H* and indentation gage *G* is positive, no matter what indentation is being set on the right of the line. If the assembled lines are of the proper length, the projection on pawl *H* will always be carried under gage *G* by the vise jaw rack *J*.

When the mold disk advances it will contact block *P*, which will release block *Q* from engagement with the lug on the vise jaw rack pawl *C*. The teeth on pawl *C*, however, do not engage the teeth on rack *J* at this time. The line spread pawl *H*, banking at its upper end under gage *G* and at its lower end on a rest fastened to the vise jaw rack pawl *C*, holds the vise jaw rack pawl down out of engagement with rack *J*. As the spacebands are driven up for expansion, however, the right vise jaw and rack *J* are moved to the left. Pawl *H*, fastened to rack *J*, also moves to the left until it clears indentation gage *G*. The projection on pawl *H* then moves up in front of gage *G*, as shown in Fig. 15, permitting pawl *C* to engage the teeth on rack *J*. As soon as pawl *C* engages rack *J*, the movement of the right vise jaw towards the left is halted and the jaw is locked in the position required for the desired indentation on the right. No matter what indentation is being set on the right, this basic sequence of actions is always the same. The line is spread out towards the left, pawl *H* is moved past gage *G* and pawl *C* rises and engages the teeth on rack *J*, locking the right vise jaw in the position required for the desired indentation. The

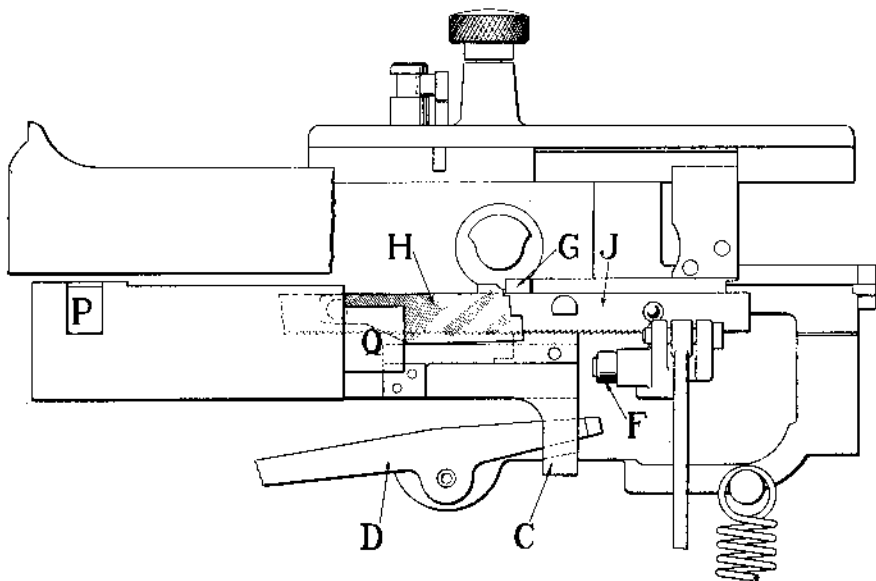

Fig. 15.—View of the Justified Quadding Attachment just after first justification. The spreading of the line between the vise jaws has carried rack *J* and pawl *H* to the left. The projection on pawl *H* has cleared gage *G*, permitting the teeth on pawl *C* to engage the teeth on rack *J*. This locks the right vise jaw in the position corresponding to the indentation setting on the Justified Indentation Scale.

parts of the justified quadding attachment are shown in these positions in Fig. 15.

If a line is set short at least  $3\frac{1}{2}$  ems of the length indicated on the assembler slide scale, the projection on pawl *H* is carried past the indentation gage *G* when rack *J* pulls the right vise jaw to the right. When the mold disk advances and contacts block *P*, therefore, pawl *C* rises immediately and engages the teeth of rack *J*. This locks the right vise jaw in position and quads out the matrix line, which is held tightly between the vise jaws during first and second justification. If there are at least two spacebands of ordinary thickness in the line the machine will cast. It should be noted that in the case of a justified line the projection on pawl *H* rises to the left of gage *G*, as shown in Fig. 15. In the case of a quadded line, the projection rises to the right of gage *G*. If there is an insufficient number of spacebands in the line to justify it completely, pawl *H* will not pass gage *G* at the left and the result will be a loose line which will not cast.

Between the first and second justification, the matrix line is loosened for vertical alignment. As the vise closing link descends, the left vise jaw is permitted to open slightly. The link continues its downward movement until roll *F*, Fig. 15, carries latch *D* down on pawl *C*. Pawl *C* is then depressed slightly to permit approximately .020" freedom between the teeth of the pawl and rack *J*. After the matrix line has been aligned vertically and facewise the vise closing link rises, closing the left vise jaw. The teeth on pawl *C* engage the teeth on rack *J* tightly and second justification takes place. The matrix line is spread out fully between the vise jaws, then the pot locks against the back of the mold and the slug is cast. The matrix line is held tightly between the vise jaws during the cast and until after the withdrawal of the slug by the wedging action of the spacebands and the inward pressure of the vise closing screw. The rack *J* is held in position by the engagement of the teeth on pawl *C* with the teeth on the rack.

After the slug has been ejected from the mold, the vise closing link descends sufficiently to latch pawl *C* under block *Q*. The operating rack *J* and the right vise jaw are returned to normal position by the jaw operating lever.

**Adjustment of Shifting Cam Bushing.** The shifting cam bushing *L*, Fig. 14, is the only part of the justified quadding attachment which requires adjustment. *The setting of the bushing, however, is highly important* because it determines within very positive limits the accuracy of the right-hand indentation. The hole in the bushing through which shaft *S* passes is eccentric. Turning the bushing will move lever *A* slightly to the right or to the left when the high point of cam *E* is banking against the mold disk locking stud block *I* as shown in Fig. 14. Since pawl *C* is pivoted on a hinge pin *N* in lever *A*, the pawl will also move a corresponding distance to the right or left. The relationship of pawl *C* to rack *J* and consequently the accuracy of the indentions made by the right vise jaw are thus controlled by the bushing *L*.

If there is an error in the right-hand indentation, it can be eliminated very easily by adjusting the bushing. Before adjusting the bushing, however, the

setting of the right vise jaw stop screw should be checked. This screw determines the position of the type line in relation to the right end of the slug body. When fully justified lines are being cast with lever *A*, Fig. 13, to the right, the screw should be adjusted so that the last character on the right end of the slug is flush with the slug body. This setting is basic and should always be checked before attempting to adjust the shifting cam bushing *L*.

After the stop screw setting has been verified, bushing *L*, Fig. 14, can be adjusted to correct the setting of the right-hand indentation. Move operating lever *A*, Fig. 13, to the right and turn knob *B* until pointer *C* registers with zero on the Normal Scale *E*. Place a strip of thin paper measuring approximately .002" between the right vise jaw and the stop screw against which the jaw banks in normal position. Make sure that the jaw is pushed all the way over to the right against the paper and the screw. Trip block *P*, Fig. 14, so that pawl *C* will rise and engage the teeth of rack *J*. Loosen set screw *M* and turn bushing *L* until the paper binds slightly as it is pulled up from between the jaw and the stop screw, then tighten screw *M*. After this basic relationship has been established, a slightly finer adjustment may have to be made. Cast two slugs with an indentation of one em on the right and one em on the left. Place the slugs back to back to see if the extreme characters on each end of the slugs coincide in position. If they do not, the shifting cam bushing should be turned slightly until the indentions are uniform.

**Line Spread and Indention Rack Gear Lock.** The indention gage *G*, Fig. 14, and the line spread pawl *H*, as previously described, control the engagement of the vise jaw rack pawl *C* with the vise jaw rack *J*. The relationship of pawl *C* to rack *J* is highly important. If the teeth of the pawl do not engage the proper teeth of the rack, there will be an error of one-half em in the right-hand indentation. The meshing of the pawl teeth with the rack teeth can be delayed or advanced slightly by shifting gage *G* to the right or to the left with respect to the projection on pawl *H*. The position of gage *G* is controlled by the line spread and indention rack gear lock *K*, which locks the gage and pointer *C*, Fig. 13, in position when knob *B* is dropped. The rack gear lock is set at the factory and is doweled in position.

In setting the rack gear lock, operating lever *A*, Fig. 13, is moved to the left and pointer *C* is moved to the Justified Indention Scale. The pointer can be set on any desired measure while making this adjustment. Next, the right vise jaw retaining latch is raised and rack *J*, Fig. 14, is pulled to the right until the projection on pawl *H* is carried under gage *G*. Then block *P* is pushed in to raise rest *Q* off the auxiliary lug on pawl *C*. When the parts are moved in this way by hand, they are placed in the positions that they would assume just before first justification. The jaw operating rack *J* is then moved slowly to the left until the projection on pawl *H* is just about to drop off gage *G*, as shown in Fig. 16. This precise relationship is indicated by the arrow *1*. When the parts are in this position, the rack teeth which are *not* to engage with the pawl teeth should be  $1/64$ " in advance of the pawl teeth as shown in the detail drawing. Thus, when pawl *H* drops off gage *G* and permits pawl *C* to rise

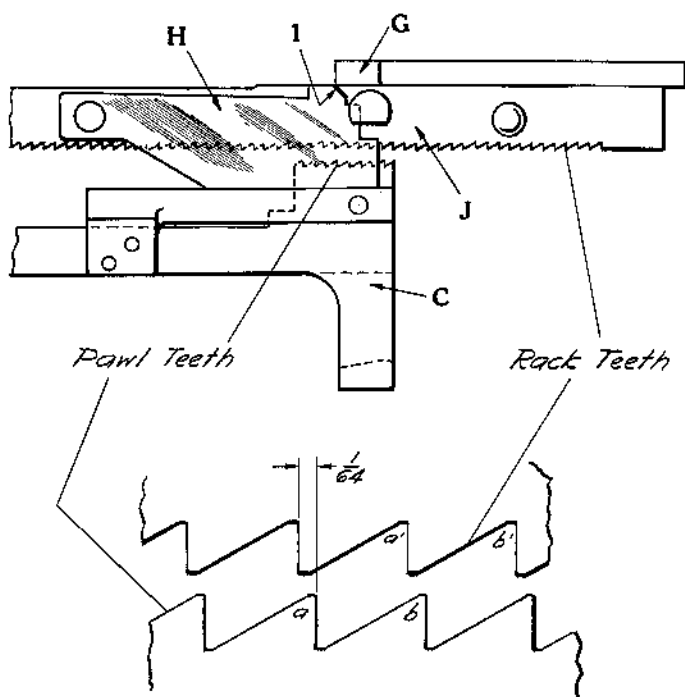

Fig. 16.—Detail view showing the position of the justified quadding parts when the line spread and indentation rack gear lock is doweled in position.

toward the rack, tooth *a* will engage tooth *a'*, tooth *b* will engage tooth *b'*, etc. To obtain this  $1/64''$  relationship, gage *G* is moved slightly to the right or to the left in relation to pawl *H*. The gage is moved by shifting the rack gear lock *K*, Fig. 14, toward the front or back of the machine. Moving gage *G*, Fig. 16, to the right will advance the engagement of pawl *C* with rack *J*. Moving the gage to the left will have the opposite effect. After the  $1/64''$  relationship of the pawl teeth to the rack teeth has been obtained and pawl *H* is just ready to drop off gage *G*, the rack gear lock *K*, Fig. 14, is doweled in position. One setting of the lock is all that is required. When the lock is positive for an indentation of one length on the right, it is positive for indentions of all other lengths.

The Intertype autospacer equipped with the justified quadding attachment is a completely universal mechanism. It makes possible a great saving in time and effort hitherto required for composition of all types. The device produces work of unrivaled precision and excellence. The Intertype autospacer and justified quadding attachment represent a progressiveness in research and strength in design which have always characterized Intertype equipment.

## INTERTYPE CORPORATION

---

360 Furman Street, Brooklyn 2, N. Y.

536 South Clark Street, Chicago 5, Ill.

1007 Camp Street, New Orleans 10, La.

500 Sansome Street, San Francisco 11, Cal.

1220 South Maple Avenue, Los Angeles 15, Cal.

80 Federal Street, Boston 10, Mass.

Toronto Type Foundry Co. Ltd., Canada